

1 to 8 Channel Precision Power Meter LMG500

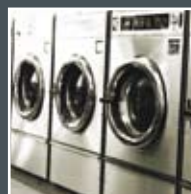

- Accuracy 0.03%
- Bandwidth 10MHz (DC, 0.05Hz to 10MHz)
- 3MSamples/s simultaneously on each U and I channel
- Sampling absolutely gapless with evaluation of all sampling values, therefore captures all inrush currents and signal changes
- Harmonics and interharmonics up to 50kHz/1MHz
- Flicker, interactions between network and load

To improve Motors, Transformers,
Frequency Inverters, Power Electronics,
Power Supplies, Lightings, Automotives
in Efficiency, Reliability,
Electromagnetic Compatibility and Life-Cycle Costs



LMG – A Synonym for Precision Power Measurement

Precision Power Meters (German: Präzisions-LeistungsMessGeräte) of the series **LMG** by ZES ZIMMER – LMG90 and LMG95 for single phase, LMG310, LMG450 and **LMG500** for multiphase measurements – have been proved in many various applications. The character string **LMG** has become a synonym for precise and wide band measurement of electrical power. The magnitudes correlated with electrical power like current, voltage, harmonics, flicker and energy have to be acquired precisely as to optimise your products in efficiency, reliability, electromagnetic compatibility (EMC), life-cycle costs.

LMGs are used for measurement at:

- Components, e.g. ferrite cores, semiconductors, capacitors
- Devices, e.g. motors, inverters, lightings
- Installations and parts of those, also power grids to identify their parameters
- CE-mark tests on devices, supplied by power sources (simulating an ideal power network), to investigate the feedback of harmonics and flicker (load variations)
- Interactions of network and appliance

The most important highlight features of the LMG500:

- Group delay between U- and I- measuring input <3ns as standard to assure very precise measurement at low $\cos\varphi$ and/or high frequencies
- High dynamics in level control, ranges from 3V to 1000V/3200V_{peak}, 20mA to 32A/120A_{peak} in direct measurement only by a single pair of sockets each for voltage as well as for current input
- 3MSample/s, absolutely gapless sampling with evaluation of all sampling values
- Capturing transients and fast signal changes by event triggering which is always active in the background of the „normal mode“
- Harmonics and interharmonics up to 50kHz internal and up to 1MHz with an external PC
- Flicker measurement, interactions between network and load
- Modular with 1 to 8 power measuring channels
- Ergonomic operation shell for easy, intuitive use of the power meter
- Real-time evaluation of the measurements in numeric tables and diagrams
- Interfaces with high data transfer rate (IEEE488.2, RS232, USB, Ethernet)

Measuring inputs for ultimate requirements



- Separated HF current inputs I_{HF}^* : 150mA to 1.2A/DC to 10MHz

- Current inputs I^* , high dynamic of range: 20mA to 32A/120A_{peak} by only one socket pair, no need and incommode change of external shunts!



- Measuring with external sensors: Inputs I_{Sensor} and U_{Sensor} 30mV to 4V/DC to 10MHz

- Voltage inputs U^* : 3V to 1000V/3200V_{peak}

- Auxiliary voltage $\pm 15V$ and Identification of external sensors

- Very low capacity of measurement inputs against earth <30pF, thereby no interference of measured signals
- High bandwidth of 10MHz, shortest pulsed signals will be measured precisely
- All inputs isolated against each other and against earth (max. 1000V/CAT III)
- Gapless sampling and evaluation with 3MSamples/s at any duration, measuring cycle max. 60s
- Up to 8 power measuring channels with 8 channel compact meter or with two connected LMG500, all channels absolutely synchronously sampling with 3MSamples/s

Flexible use of the power measurement channels

Eight power measurement channels, each of them sampled absolutely synchronously with 3MSamples/s, can be provided:

- Either by a coupled 2nd device
- Or by the LMG500 with its compact 8 channel enclosure.

The current and the voltage paths of the power measurement channels are all isolated against each other and against

earth. This enables a free structuring of measurement on various power applications. The channels are arranged within up to 4 groups (see listed table): channels 1 to 4 (device 1) into group A and B and channels 5 to 8 (device 2) into group C and D. Each group is synchronised by a group specific signal. The synchronisation with an external signal or by „line“ is also possible. The settings of group A and B for certain wirings are independent to the settings of group C and D.

Channel No.	Ch. 1	Ch. 2	Ch. 3	Ch. 4	Ch. 5	Ch. 6	Ch. 7	Ch. 8
Group formation	A		B		C		D	
Possible wiring in the groups A to D	4Ø 4Wire				4Ø 4Wire			
	4Ø 5Wire				4Ø 5Wire			
	1Ø 2W	1Ø 2W	1Ø 2W	1Ø 2W	1Ø 2W	1Ø 2W	1Ø 2W	1Ø 2W
	3Ø 3Wire			1Ø 2W	3Ø 3W			1Ø 2W
	3Ø 4Wire				3Ø 4W			
	4Ø 4Wire			4Ø 4W				
	3Ø 3W (Aron)/2Ø 3W		3Ø 3W (Aron)/2Ø 3W		3Ø 3W (Aron)/2Ø 3W		3Ø 3W (Aron)/2Ø 3W	
3Ø 3W (Aron)/2Ø 3W		1Ø 2W	1Ø 2W	3Ø 3W (Aron)/2Ø 3W		1Ø 2W	1Ø 2W	

LMG500 – Compact with 8 Channels



Hybrid Automotive Drives

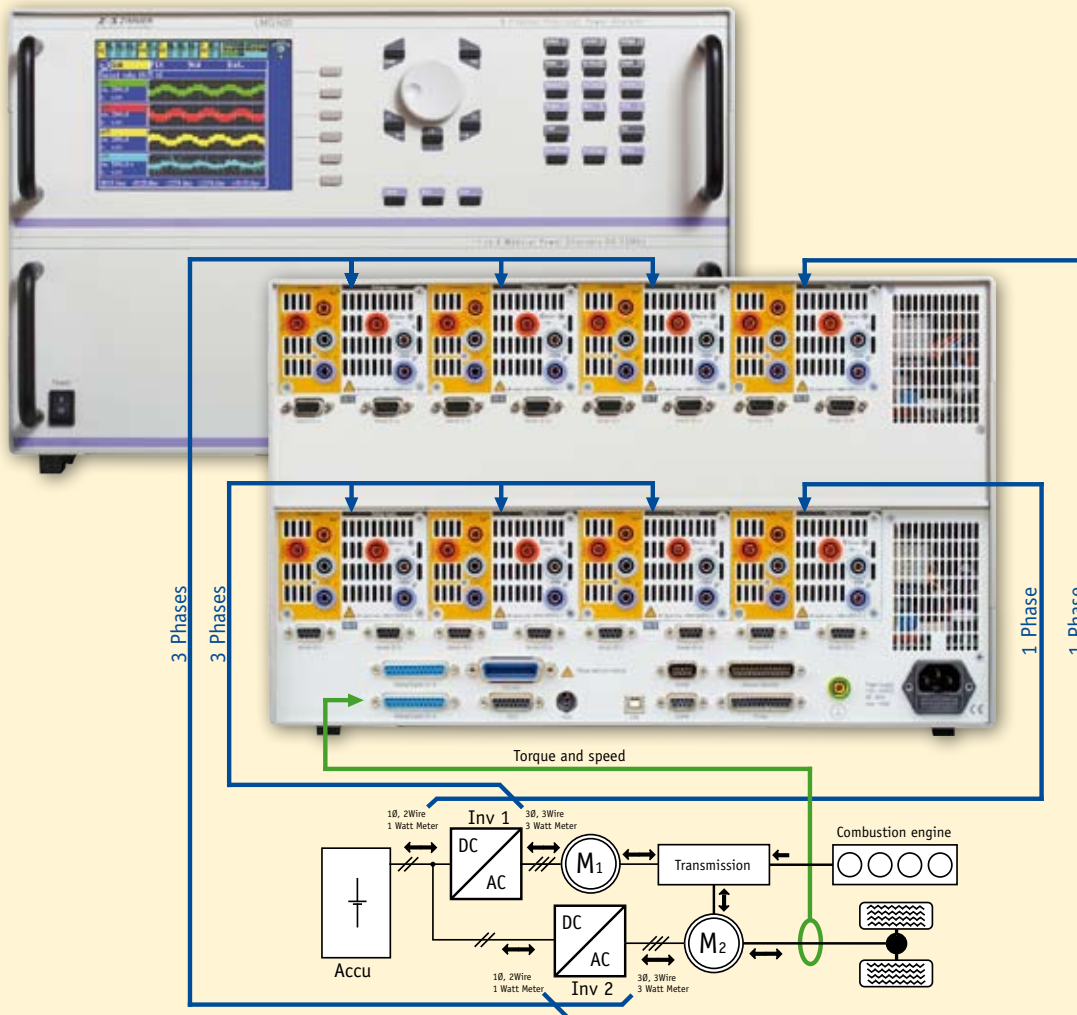

Optimisation of the energy management of hybrid automotive drives through analysing the power flow in various operation modes and conditions:

1. Automotive drives through combustion engine with or without booster of the inverter fed 3-phase electrical machines M1 and M2.

2. Energetic feedback of the braking energy into the battery.
3. Charging/recharging of the battery with combustion engine. Eight power measurement

channels and the process signal interface for torque and speed acquire exactly synchronously all data to precisely define efficiency.

LMG500 – Compact with 8 Channels



Uninterruptible Power Supply with DC-Link

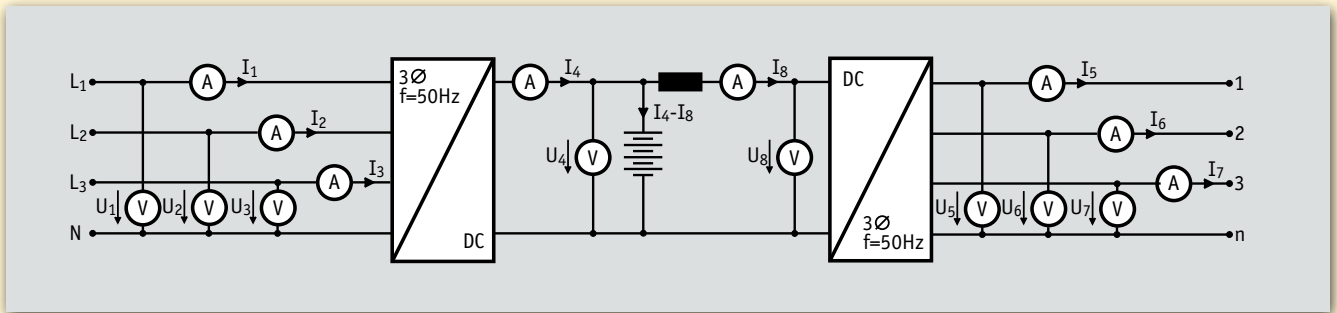

Determination of efficiency at different operation points and conditions



Double Fed Asynchronous Machines

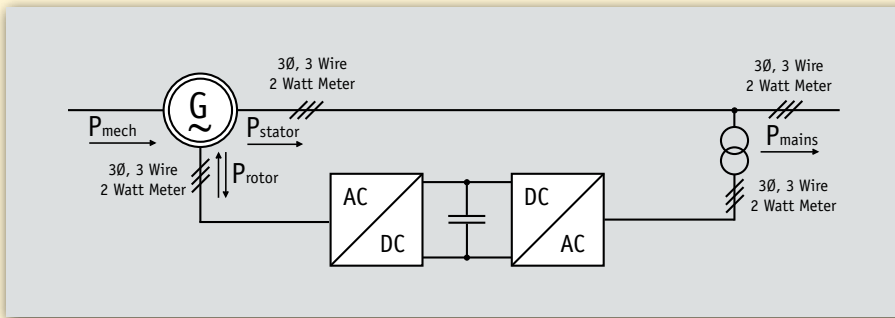

Stator power, rotor power, mains power, mains specific inverter power in each case with two watt meters in Aron circuit

Wind generators without gearing but with an extended range for revolution speed.

With fixed frequency at stator side and by setting the rotor frequency the double fed asynchronous machine can work as a generator with high efficiency at different wind speeds.



Transformers with Multiple Windings

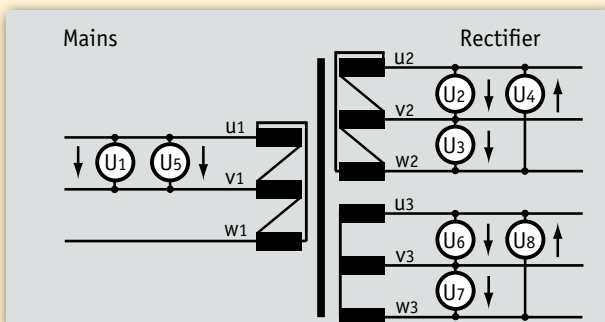

Eight channel measurement at 12pulse rectifier transformer

A three winding transformer with two by 30° electrically shifted outputs coils feeds two 6puls rectifiers. Thereby the primary winding suppresses harmonics, e. g. the 5th, 7th, 17th and 19th. The power measurement channels are configured as two groups with channels 1 and 5 in parallel. Therewith all measurement channels have the same phase reference and special rectifier transformers with (n·30°) deviating phase angles can be measured exactly.

Gapless Data Capturing



Energy Efficiency Classification for White Goods and PCs Standby Consumption

Benchmark like SPECpower_ssj2008 have been set up to ascertain power consumption of PCs and servers as a function of computing power. The LMG500 is listed for this. Standby consumption of domestic appliances are covered by standards like IEC 62301. The LMG500 fulfils this requirements. Low currents (µA) can be measured by using the shunt SH-100-P.





Power Loss of Filters for Frequency Inverters

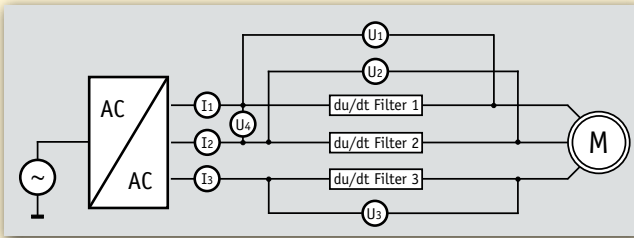

Power loss through measurement across the filter

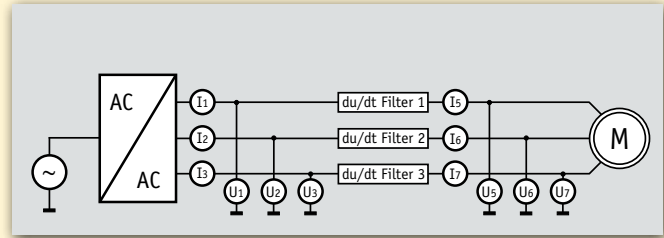

Power loss through difference measurement before and behind the filter

To increase efficiency of modern PWM frequency inverters fast switching semiconductors are used for minimising the switching losses in the output stage. However, the extremely steep voltage edges cause capacitive currents that stress bearings and isolation of the motors – this leads to an early break down. Motor filters (e. g. du/dt-filters) attenuate the voltage edges in rise and fall, but generate power losses by the filters' transient oscillations (typ. >100kHz). The high bandwidth and the very small group delay time of U-/I-measuring channels, <3ns as standard, allows extremely precise power loss measurements at those frequencies, also when measured across the filter at small $\cos\phi$.

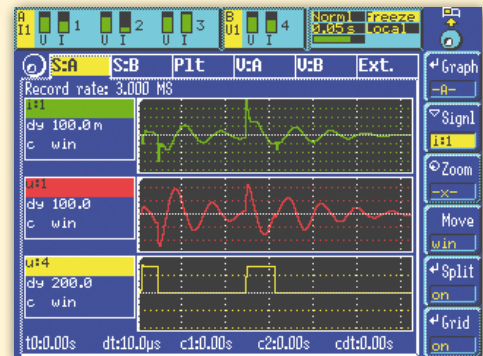

L-L voltage U4 before the filter, voltage U1 across the filter and filter input current I1

Menu to compensate the delay time of external sensors

Currents >30A are measured by means of external sensors. Wide band (>100kHz) current transducers for more than 100A, e. g. ZES ZIMMER type PSU, are used. The error caused through the group delay of the current transducer can be corrected by assistance of the delay time menu inserting the necessary time adjustment. An outstanding tool with an easy to use menu.

	dU/ns	dI/ns	P/W	PF
1	0	10	0.0403 kW	0.04799
2	0	3	0.0452 kW	0.05418
3	0	7	0.0379 kW	0.04831
4	0	0	0.0000 kW	-----
5	0	0	-----	-----
6	0	0	-----	-----
7	0	0	-----	-----
8	0	0	-----	-----

Delay time menu with compensation values for I in phase 1,2 and 3



Losses at lowest power factors of transformers, chokes and capacitors

Power measurement up to 10MHz requires that current and voltage channels are so designed that delays between each other are very small. With the LMG500 they are less than 3ns and this means an angle error <1 μ rad at 50Hz. Due to this feature incorporated in the LMG500 it is best suited to measure the power losses of transformers, chokes and capacitors at very low power factor. The instruments with the standard factory settings fully comply to the requirements of these measurements. Options or adjustments are not necessary.

A calibration protocol [order no. KR L50 LPF] to proof measurement accuracies at power factors in the range of 0.01 can be supplied. Usually current or voltage transducers will be used for measuring power transformers. The phase angular error of this transducers can be corrected in the delay time menu which improves the accuracy of the measurement. Various definitions, e.g. IEC 60076-1, can handle the calculation of the corrected power. This can be calculated easily by using the powerful formular editor regarding to the requirements.



Source: Siemens AG

Core Losses and Parameters up to 10MHz

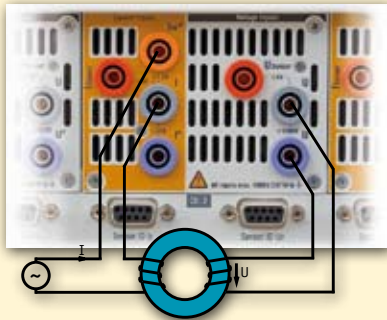

Circuitry

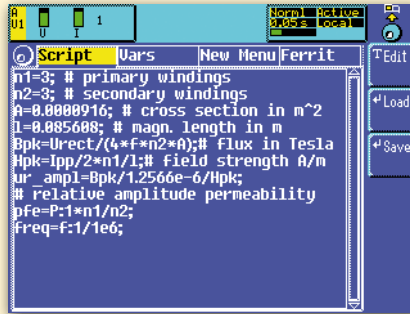

Script editor



Custom menu with numerical results

The power measured with the exciting current I and the induced voltage U at the sensor winding (core magnetisation voltage) directly yields the core losses without copper losses. With the rectified value of the sensor voltage U – a measure for the voltage-time area and therewith the induced flux \rightarrow , the exciting current I and the geometric core data, the characteristic curves e.g. $P(B_{pk})$, $B_{pk}(H_{pk})$ can be generated. With the high-performance script editor the respective curve points are calculated measuring cycle by measuring cycle. Please request special application note.

Chopped Ballasts of Modern Lighting

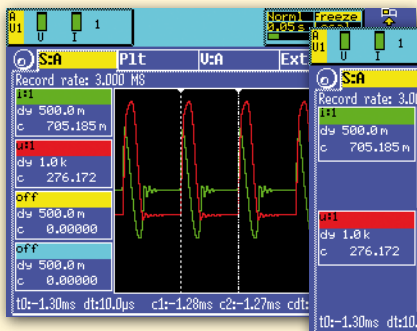

Wave forms of current and voltage



Custom menu with numerical results



Modern flat panel lamp

Due to the low earth capacitance of the LMG500 measuring inputs (<30pF) pulsed currents and voltages can directly be measured and displayed on the LMG500 screen without any deviation. The figures show the 70kHz pulses ($U_{pp}=2.5kV$, $I_{pp}=2.7A$) that permanently ignite and therewith keep ionisation of the gas discharge flat lamp (light tile) alive. Only based on the very small group delay difference of U and I channel, <3ns as standard, precise power measuring can be effected at this sample with its challenging signals.

Transient Currents at the Output of a Frequency Inverter

Through the high bandwidth of 10MHz high-frequency current peaks at the frequency inverter output can be sampled and visualised. Transient current peaks are produced on each switching edge – currents which flow via the winding capacitance. They yield a multiple of the nominal current. You will get the high ratio from the values I_{pp1} and I_{trms1} from the shown custom menu.

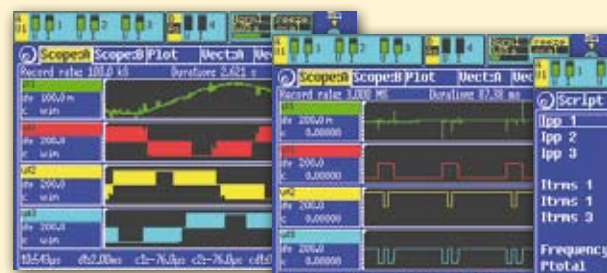

Line current and the three line to line voltages

Extra high current peaks at simultaneous switching edges



Custom menu with numerical results



Transient Voltages with Long Connecting Lines

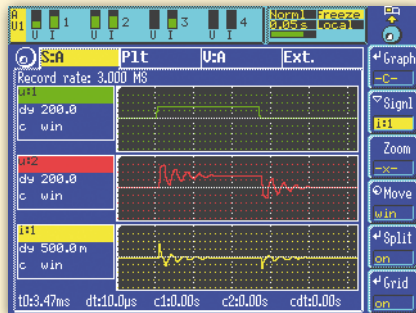

Voltage at inverter output as well as voltage and current at motor with long connection cables

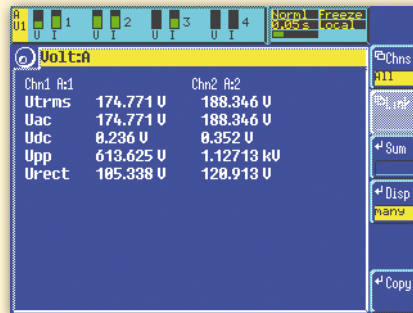

Easy to recognize: Double increase of peak value U_{pp}

Voltage peaks by reflexion occur on long connection cables between frequency inverter and motor. They attain up to the double of the transmitted voltage pulse and stress isolation in addition. On account of the high bandwidth of the LMG500 these voltage peaks are captured properly.

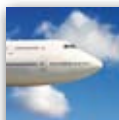

Avionics: Monitoring Harmonics up to 150kHz

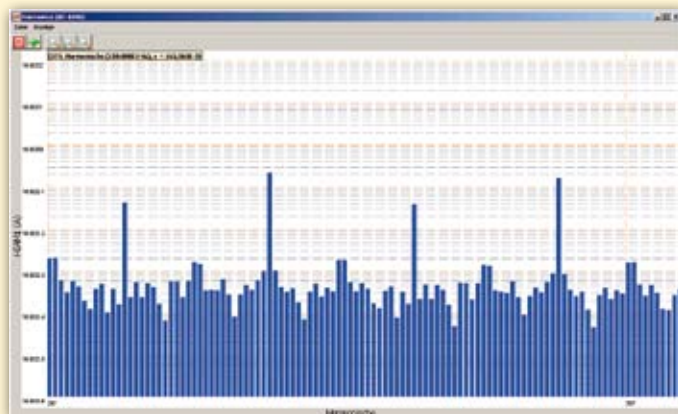

Harmonic Analysis by ZES ZIMMER software LMG-CONTROL

The on-board power supplies of modern large scale aircraft are operating with frequency up to 800Hz. Basic standards like EUROCAE ED-14D and ABDO100.1.8 are created to define limit values, as to specify those power supplies. Fundamental frequency from 360Hz to 800Hz must be assessed by their harmonics in ranges up to 150kHz. Therefore the LMG500 is best applicable.

The spectral analysis of currents and voltages DC to 1MHz is supported by a separate ZES ZIMMER application software LMG-CONTROL. You will get graphical data representation in linear or logarithmic scaling. The values can also be exported as tables e. g. into MS Excel.

Harmonic analysis with LMG-CONTROL ranges up to 1MHz. The fundamental can be set user-defined from 0.07Hz to 1MHz.

High Basic Accuracy – High Range Dynamics

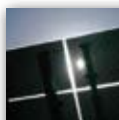

Solar Technology

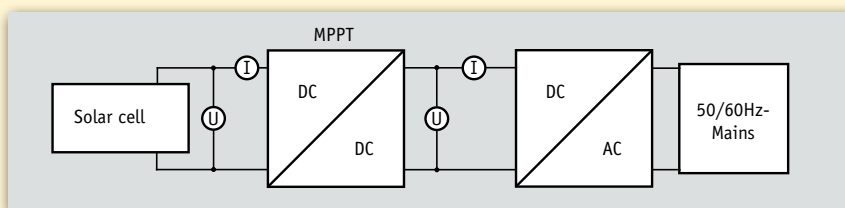

By assistance of the Maximum Power Point Tracker (MPPT) the operating point of a solar generator can always be kept in its optimum. While non steady solar radiation currents and power can vary between a few percent and nominal value in short time intervals. The tracking can only be optimised if measuring is consistently and without dropout e.g. that may occur while measuring range is switched. The high nominal accuracy of 0.03% allows a correct measuring of very low currents also in the 32A range.

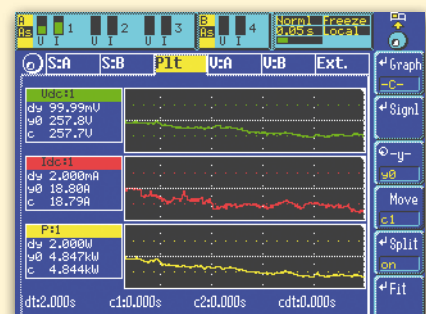

Voltage, current and effective power high precise without range switching

High Quality Basic Configuration

The high quality basic configuration of the LMG500 at reasonable price allows comfortable working. Already included are RS232 interface, a printer interface and a powerful script editor.

Options and Accessories for Operating Extensions

IEEE488 interface

(Order no. L50-01)
Interpretation of the complete SCPI, as well as the LMG500 specific command set. The data transfer rate yields up to 1Mbyte/s.

USB interfaces

(Order no. L50-02USB)
For connection of a memory stick (front side) and another USB interface for data transfer and remote (backside).

Ethernet converter

(Order no. L50-Z318)
External adapter, all connectors will fixed and supplied by LMG.

Processing signal interface, digital and analogue in- and outputs

(Order no. L50-03)
To monitor further process magnitudes like revolution, torque etc. With assistance of the script editor efficiency and other magnitudes can be deduced and be applied as control parameters.

Flicker meter

(Order no. L50-04)
Compliant to EN61000-4-15. The evaluation of the voltage fluctuations by currents up to 16A compliant to EN61000-3-3, by currents up to 75A compliant to EN61000-3-11.

Event triggering

(Order no. L50-05)
Display and save abnormal events. Further description see below.

Star to delta conversion

(Order no. L50-06)
for 3phase-3wire systems. Further description see below.

Harmonics up to 99th for U, I, P, Q and S

(Order no. L50-08)
Current, voltage and power are analysed up to 50kHz on fundamentals ranging from 0.1Hz to 1.2kHz. Evaluation of inter-harmonics is possible by dividing the given fundamental to a

lower one using it as reference. With use of the sampling values the harmonic analysis up to 1.5MHz on a external PC is given.

CE Harmonics (Order no. L50-09)
Up to the 40th, for currents up to 16A in compliance with EN61000-3-2, for currents from 16A to 75A in compliance with EN61000-3-12

DSP Modules(Order no. L50-010)
Necessary to operate particular options.

Option: Event triggering

Order no. L50-05

If trigger conditions are set this option operates in the background of the normal measuring mode and can be conditioned for max. four measurement values u, i, p coming from different measuring channels. By detection of given trigger conditions the scope display will be „frozen“ (display „finish“ in the status line). However, the normal measuring proceeds without any gaps, evaluating completely all sample values. Four logical connectable trigger events, which are selected via the menu, can be defined to control the U- and I measuring inputs. In each trigger event you can ascertain: Value larger/smaller, inside of/outside of a window, event time 330ns...10s. By this and the sampling with 3Msamples/s particular peaks and dips will be detected. Via the printer interface the aligned scope picture can be printed, also the 2 million samples representing the event can be transferred via the data interface, on request. With the soft key button RUN the scope display is switched again to the current measuring mode until a new event is detected.

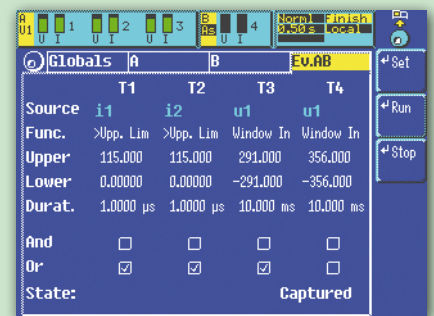

Conditioning of event triggering

Option: Star to delta conversion for 3phase-3wire system

Order no. L50-06

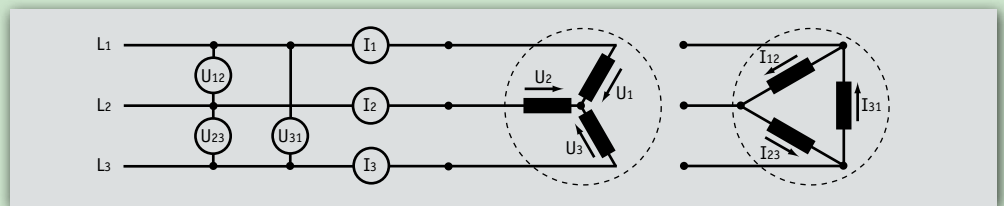

3phase-3wire system: measurement of line to line voltages and line currents

At 3phase-3wire systems only the line to line voltages U_{12} , U_{23} and U_{31} and the line currents I_1 , I_2 and I_3 are available for measurement.

By assistance of the star to delta conversion the line to line voltages can be converted into those not directly accessible phase voltages (line to neutral voltages, i. e. the phase voltages of the load as if star-connected) and the assigned active powers can be defined. In analogy the line currents can be converted into the „linked“

currents (line to line currents of the delta connected load). Out of the calculated „linked“ values other magnitudes are

deduced, as well as harmonics can be assessed. Unbalance of net and load, as well as distorted wave forms are

handled correctly by the star to delta conversion.

Link123 (U1,I1) A:9	Link123 (U2,I2) A:10
Itrms 0.88827 A	0.88827 A
Utrms 68.719 U	68.795 U
P 4.855 W	4.352 W
Q 3.739 var	4.236 var
S 5.516 VA	6.873 VA

Link123 (U3,I3) A:11	Sum(9-11) A:15
Itrms 0.87388 A	0.14829 A
Utrms 68.746 U	119.884 U
P 3.844 W	12.251 W
Q 3.318 var	11.358 var
S 5.873 VA	16.786 VA

Calculated values (linked values) of the star connected windings (Wiring: 3+1, $U_{\Delta} I^* \rightarrow U^* I^*$)

Link123 (U12,I12) A:9	Link123 (U23,I23) A:10
Itrms 0.84762 A	0.84681 A
Utrms 118.284 U	119.383 U
P 4.278 W	4.881 W
Q 3.658 var	3.758 var
S 5.629 VA	5.489 VA

Link123 (U31,I31) A:11	Sum(9-11) A:15
Itrms 0.84455 A	0.87981 A
Utrms 119.119 U	285.988 U
P 4.853 W	12.332 W
Q 3.426 var	18.861 var
S 5.387 VA	16.433 VA

Calculated values (linked values) of the delta connected windings (Wiring: 3+1, $U_{\Delta} I^* \rightarrow U_{\Delta} I_{\Delta}$)

Options and accessories for expanding functions

Adapter for incremental rotary encoder

Order no. L50-Z18

Pulses of the incremental rotary encoder (signal u2 in blue) are transformed to a proportional voltage by the adapter L50-Z18, positive/negative voltage for forwards/backwards, and led to the LMG500 measuring input, here the I_{sensor} input.

Interesting details in the scope display that has been captured (status „finish“) with the option „event triggering“: u1 (red) is the motor voltage, i1 (yellow) is the motor current which rises with the electrical time constant of the rotor. About 0.7ms after applying current the motor starts with its first move and the rise of the analogue, revolution-proportional adapter output signal i2 (green) begins. 3.5ms after start up of the motor current, the rotor has moved only 8°, the rotation speed of 126U/min is already exactly received!

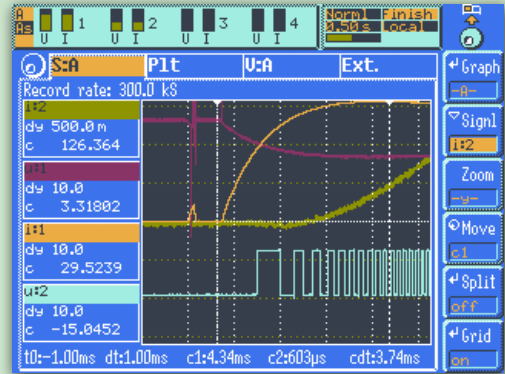

Rotary encoder via adapter L50-Z18 connected to a measurement channel to record a fast motor start with high resolution

SYS61K Test system in compliance with EN61000-3-2/-12 and EN61000-3-3/-11

Order no. SYS61K-3PL50

System to measure current harmonics and flicker emitted by the appliance and their effects onto mains:

- harmonic analyzer acc. EN61000-4-7
- harmonics for currents up to 16A in compliance with EN61000-3-2
- harmonics for currents from 16A to 75A in compliance with EN61000-3-12
- flickermeter acc. EN61000-4-15
- flicker (voltage fluctuation) for currents up to 16A in compliance with EN61000-3-3
- flicker (voltage fluctuation) for currents up to 75A in compliance with EN61000-3-11

The system consists of:

- a ZES ZIMMER power meter LMG500
- an AC source, as an alternative customer can implement own sources
- a reference impedance
- measuring analysis software in compliance with standards
- a PC/notebook

Ready to use delivery in a 19" cabinet or as hard-/software package for customer system integration, also with customer components



SYS61K Test system in compact 19" cabinet

Technical Data

Voltage measuring ranges U*

Nominal value /V	3	6	12.5	25	60	130	250	400	600	1000
Maximum trms value /V	3.6	7.2	14.4	30	66	136	270	560	999	1001
Maximum peak value for full scale /V	6	12	25	50	100	200	400	800	1600	3200
Input impedance	>4.5MΩ <3pF									

Current measuring ranges I*

Nominal value /A	20m	40m	80m	150m	300m	600m	1.2	2.5	5	10	20	32
Maximum trms value /A	37m	75m	150m	300m	600m	1.25	2.5	5	10	20	32	32
Maximum peak value for full scale /A	56m	112m	224m	469m	938m	1.875	3.75	7.5	15	30	60	120
Shunt impedance	560mΩ			68mΩ			7.5mΩ			2mΩ		

Current measuring ranges I_{HR}*

Nominal value /A	150m	300m	600m	1.2
Maximum trms value /A	225m	450m	900m	1.8
Maximum peak value for full scale /A	313m	625m	1.25	2.5
Shunt impedance	0.1Ω			

Sensor inputs U_{Sensor}, I_{Sensor}

Nominal value /V	30m	60m	120m	250m	500m	1	2	4
Maximum trms value /V	37m	75m	150m	300m	600m	1.2	2.5	5
Maximum peak value for full scale /V	62m	125m	250m	500m	1	2	4	8
Input impedance	100kΩ 34pF							

Measuring accuracy

Accuracy	DC	± (% of measuring value + % of measuring range)									
		0.05Hz..45Hz	45Hz..65Hz	65Hz..3kHz	3kHz..15kHz	15kHz..100kHz	100kHz..500kHz	500kHz..1MHz	1MHz .. 3MHz	3MHz .. 10MHz	
Voltage	U* Usensor	0.02+0.06 0.02+0.06	0.02+0.03 0.015+0.03	0.01+0.02 0.01+0.02	0.02+0.03 0.015+0.03	0.03+0.06 0.03+0.06	0.1+0.2 0.2+0.4	0.5+1.0 0.4+0.8	0.5+1.0 0.4+0.8	3+3 f/1MHz*0.7 + f/1MHz*1.5	f/1MHz*1.2 + f/1MHz*1.2 f/1MHz*0.7 + f/1MHz*1.5
Current	I* (20mA .. 5A) I* (10A .. 32A) I HF I sensor	0.02+0.06 ↓ ↓ ↓	0.015+0.03 ↓ ↓ ↓	0.01+0.02 ↓ ↓ ↓	0.015+0.03 ↓ ↓ ↓	0.03+0.06 0.1+0.2 0.03+0.06 0.03+0.06	0.2+0.4 0.3+0.6 0.2+0.4 0.2+0.4	0.5+1.0 f/100kHz*0.8 + f/100kHz*1.2 0.5+1.0 0.4+0.8	0.5+1.0 f/1MHz*1 + f/1MHz*2 0.5+1.0 0.4+0.8	f/1MHz*1 + f/1MHz*2 - f/1MHz*1 + f/1MHz*2 f/1MHz*0.7 + f/1MHz*1.5	- - - f/1MHz*0.7 + f/1MHz*1.5
Power	U* / I* (20mA .. 5A) U* / I* (10A .. 32A) U* / I HF U* / I sensor U sensor / I* (20mA .. 5A) U sensor / I* (10A .. 32A) U sensor / I HF U sensor / Isensor	0.032+0.06 ↓ ↓ ↓ ↓ ↓ ↓ ↓	0.028+0.03 ↓ ↓ ↓ 0.024+0.03 ↓ ↓ ↓	0.015+0.01 ↓ ↓ ↓ ↓ ↓ ↓ ↓	0.028+0.03 ↓ ↓ ↓ 0.024+0.03 ↓ ↓ ↓	0.048+0.06 0.104+0.13 0.048+0.06 0.048+0.06 0.048+0.06 0.104+0.13 0.048+0.06 0.048+0.06	0.24+0.3 0.32+0.4 0.24+0.3 0.24+0.3 0.32+0.4 0.4+0.5 0.32+0.4 0.32+0.4	0.8+1.0 f/100kHz*1 + f/100kHz*1.1 0.8+1.0 0.72+0.9 0.72+0.9 f/100kHz*1 + f/100kHz*1 0.72+0.9 0.64+0.8	0.8+1.0 - 0.8+1.0 0.72+0.9 0.72+0.9 - 0.72+0.9 0.64+0.8	f/1MHz*3.2 + f/1MHz*2.5 - f/1MHz*3.2 + f/1MHz*2.5 f/1MHz*3 + f/1MHz*2.3 f/1MHz*1.4 + f/1MHz*1.8 - f/1MHz*1.4 + f/1MHz*2 f/1MHz*1.12 + f/1MHz*1.5	- - - f/1MHz*1.5 + f/1MHz*1.4 - - - f/1MHz*1.12 + f/1MHz*1.5

additional measurement uncertainty in the ranges 10A to 32A: $\pm I_{rms} \cdot 30 \mu A / A^2$

Accuracies based on:

1. sinusoidal voltage and current
2. ambient temperature (23 ± 3) °C
3. warm up time 1h
4. definition of power range as the product of current and voltage range, $0 \leq |\lambda| \leq 1$, (λ =Power factor=P/S)
5. calibration interval 12 month

Other values

All other values are derived from the current, voltage and active power values. Accuracies for derived values depend on the functional relationship (e.g. $S = I * U$, $\Delta S/S = \Delta I/I + \Delta U/U$)

Isolation

All current and voltage inputs isolated against each other, against remaining electronic and against earth max. 1000V/CATIII resp. 600V/CATIV

Synchronization

The measurement is synchronized on the signals period. There is a choice to determine the period from „line“, „extern“, u(t), i(t) as well as their envelopes, combined with settable filters. By this very stable readings are achieved, even at signals of pulse width modulated frequency inverters and amplitude modulated electronic ballasts

Harmonic analysis (option CE Harm L50-09)

Measuring of current and voltage with evaluation in full compliance with EN61000-3-2/-12, measurement according to EN61000-4-7

Harmonic analysis (option Harm100 L50-08)

Analysis of current, voltage (incl. phase angle) and power up to 99th harmonics, in total 100 harmonics including DC component. Fundamental in the range from 0.1Hz to 1.2 kHz. Analysis up to 10kHz (50kHz without antialiasing filter). By integer divider (1...128) a new reference fundamental can be created as to detect interharmonics. Externally on PC up to 1MHz with LMG-CONTROL software.

Flicker measuring (option L50-04)

Flicker meter according to EN61000-4-15 with evaluation in full compliance with EN61000-3-3/-11

Transients (option L50-05)

Detecting and recording of transients >330ns

Scope function (standard)

Graphical representation of sampled values versus time

Plot function (standard)

Time (Trend) diagram of max. 4 readings, minimal resolution 50ms, respectively 10ms in 50Hz half-wave (flicker) mode

Star delta conversion (option L50-06)

Sums and differences between channels on sample basis

Computer interfaces

RS232 (standard) and IEEE488.2 (option L50-01), additional USB 2.0 Typ B (L50-02USB), Ethernet 10/100 Base-T RJ45 (option L50-Z318) available. Only one interface can be used at the same time

Remote control

All functions can be remote-controlled, keyboard lock for measuring parameters

Output data

Output of all readings, data formats BIN/ASCII, SCPI command set

Transfer rate

RS232: max.115200 Baud, IEEE488.2: max. 1MByte/s

USB-stick connector (option L50-02USB)

For logging data

Printer interface (standard)

Parallel PC-Printer interface with 25-pin SUB-D socket, printing measuring values, tables and graphics to matrix, inkjet or laser printers

Processing signal interface (option L50-03)

- 2 x 25 pin SUB-D socket with:
- 8 analog inputs for process magnitudes (24Bit, ±10V)
 - 8 analog outputs (14Bit, ±10V)
 - 8 digital inputs
 - 8 digital outputs
 - 2 input for frequency (0.05Hz...6MHz) and rotation direction
 - in- and outputs are isolated against other electronics (test voltage 500V)

Other data

Dimensions/Weight

- Bench case 1 to 4 channels W 433mm x H 148mm x D 506mm / about 12kg
- Bench case 1 to 8 channels W 433mm x H 283mm x D 506mm / about 23kg
- Accessories: brackets for 19" rack, 84PU, 3HU, D 464mm

Protection class

EN61010 (IEC61010, VDE0411), protection class I

Electromagnetic compatibility

EN61326

Protection system

IP20 in accordance to EN60529

Operating/storage temperature

0...40°C/-20...50°C

Climatic class

Normal environment conditions according to EN61010

Power supply

100...240V, 50...60Hz, max. 150W (4 channel device), max. 300W (8 channel device)

LMG500 application software

(Name of software is equal with order number, please request detailed data sheets)

LMG-CONTROL

Individual configuration of measurement, using all features of the LMG500, spectral analysis, remote of LMG500, storage in MS Excel readable format (e.g. CSV-file)

Waveform analysis module

Logging and analysis of all sampling values

PQA-SOFT

Software especially designed for power quality analysis (acc. EN50160), easy configuring of measurement in a few steps

SYS61K-1/3-SOFT

Control and evaluation software for test systems of harmonics and flicker according to EN61000-3-2/-3/-11/-12

Measurement Accesories and Extensions

„Plug N'Measure“ current sensors for extended current ranges up to 5000A

Order no. and detailed datasheets on request

(1) Precision DC	0.02%	DC	to 1MHz	0.8A to 5000A
(2) Precision AC	0.02%	15Hz to 5kHz		5A to 1500A
(3) Clamp on CT	0.15%	2Hz to 50kHz		0.3A to 3000A
(4) Wideband AC	0.25%	30Hz to 1MHz		10A to 1000A
(5) Low Cost Hall	0.3%	DC	to 200kHz	0.3A to 2000A



Example to (1):
Prec. current transducers PSU700-L50 for 700A



Example to (2):
Prec. AC current transformer LMG-Z502 for 1500A



Example to (3):
Clamp-on current sensor L45-Z06 for 40A, 5Hz to 20kHz



Example to (4):
Prec. wideband current transformer LMG-Z601 for 100A, 30Hz to 1MHz



Example to (5):
Hall effect current sensors L50-Z29 Hall for 50A to 1000A

Detailed specifications and selection guide in the handbook „ZES Sensors and Accessories“, available on request.

Precision high voltage divider

Precision high voltage divider for 3/6/9/12/30kV to 300kHz, 0.05%
Negligible phase error, therefore best suited for wideband power measuring.

- 1-channel HST for single ended voltages
- 2-channel HST for floating voltages (difference measuring)
- 3-channel HST for three phases systems (inverters)

Power quality analysis in railway technology and medium-voltage systems. Insulation diagnostics by $\tan \delta$ measuring down to 0.1Hz. Suitable for outdoor application (IP65) with high over-voltage.



HST30 for 30kV, single-phase



HST12-3 for 12kV, three-phase

RS232 - Ethernet - converter, 10/100mbit

Order no. L50-Z318

External adaptor, all connectors will be fixed at the LMG, supply by LMG

Adapter for 3-phase measurements

Order no. LMG-MAK3

- CEE-Plug, 5 pins, 16A, 2m supply cord
- CEE-Socket, 5 pins, 16A, for EUT
- Socket for supplying the meter LMG500/LMG450
- 4mm safety sockets, measuring access to current and voltage
- Safety acc. IEC61010: 300V/CATIII



LMG-MAK3

M-n motor torque soft

Order no. L50-O16

Torque and speed directly calculated from measured motor current and voltage. Supplied by frequency inverters or directly by 3-phase-net. Applicable for motors acc. to IEC-standards. Accuracy from 0 to 1.5 fold nominal torque better than 2%. Configurable with plugin in LMG-CONTROL software.



PC Software

Order no. LMG-CONTROL-B

PC software for data transfer, configuration and visualisation, Modular design, saves and loads device configurations. Interactive mode to set up the measurements. Recording and storage adds timestamps with accuracy in the range of milliseconds. Analysing modules for different applications. Basic version is free of cost.

Order no. LMG-CONTROL-WA

Additional module for LMG-CONTROL, logging and analysis of all sampling values of the LMG, harmonic analysis up to 1MHz, frameanalyser, logging of transients.



Calibration certificate

Order no. KR-L50-B

Order no. KR-L50-CHN*

*For each power channel

Calibration with certificate, traceable according to ISO9000

Calibration and service package for extended warranty

Order no. L50-KSP

With the purchase of the calibration and service package the warranty will be extended every year for further 12 months according to your wishes and technical applications.

The necessary access is the calibration according to ISO9000 at first delivery of the device. After 12 months the device has to be sent back to ZES ZIMMER for a further calibration and if necessary for adjustment. Along with the calibration the appropriate maintenance work is accomplished. During the warranty period and extended warranty period

all incidental repair work is accomplished free of charge. Repairs of failures through abrasion and faulty handling are excepted from the warranty. Requirement for extended warranty and its continuation is the calibration at first delivery and the annual due in time calibration in continuity. The required extension always needs our written acknowledgement. On this way a warranty time of 10 years or longer can be achieved.



Subject to technical changes, especially to improve the product, at any time without prior notification.